



Cisco Integrated System for Microsoft Azure Stack

Sizing and Order Process Guide

Oct 3, 2017

Version 1.4



Azure Stack: *How to Quote Summary?*

Things to Know

- Azure Stack is sold as an appliance
- You cannot reuse existing equipment
- Cisco Advanced Services Installation and Solution Support are mandatory and included in the quote
 - Initially, a Statement of Work per customer is required while the price will be fixed
 - A fixed priced SKU will be added in approximately two months
- Microsoft Azure Stack is not available in all countries – this is a Microsoft restriction – so there is a compliance hold
- Cisco Solutions Support is required and configs have 12 month 24 X 7 X4 as default. Sales can adjust this 24 or 36+ months etc. A term of less than 12 months is not supported.

Azure Stack: *How to Quote Summary?*

How to quote:

1. In CCW Choose either “Config to order” or “Fixed Bundled” option Small, Medium, Large
2. If “Config to order” select:
 - Number of nodes
 - Type of processor – 6 choices
 - Memory size -3 sizes
3. If “Fixed Bundled” option select
 - Number of nodes (no other changes allowed)
4. Clear Compliance Hold with SAC
 - MSFT Country Support
 - Cisco AS inclusion – non discountable
 - Cisco Solution Support on all System Components (Nexus 93180m Nexus 2232, FI 6332, C240 M4)
 - “Deal ID” flagged as Azure Stack

Cisco Integrated System For Microsoft Azure Stack

What is it?

- A Hybrid cloud solution that enables the customer to run the Azure public cloud in their data center
- Features same API's and user interface as Azure
- Sold on a dedicated Cisco Infrastructure

Microsoft mandates:

- Specific config guidelines and certification testing
- Fixed Appliance like configurations
- Solutions Support must be sold in the BOM
- Cisco AS Installation service must be sold in the BOM
- Limits which countries the installation can take place

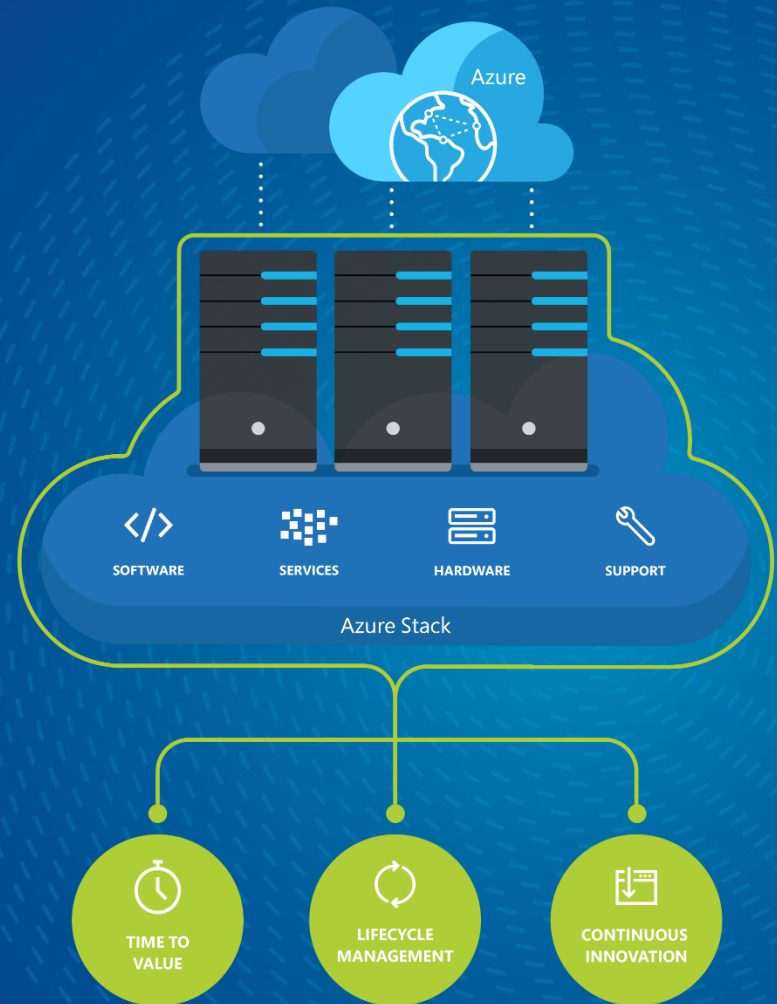

Cisco Integrated System for Microsoft Azure Stack



- 2 x Cisco Nexus 93180LC-EX Switches
- 2 x Cisco UCS 6332 Fabric Interconnects
- 2 x Cisco Nexus 2232TM-E Fabric Extenders

Reminders:

- Microsoft Scale Unit = Cluster
- Nodes configured exactly the same
- M4 and M5 servers cannot be mixed in a cluster

From 4 to 12 nodes, any increment in between

UCS C240 M4L



12 x Cisco UCS C240-M4L Rack Servers

64TB/Node is the only storage capacity offered for M4 based systems.

- 2 x 3.2 TB NVMe cards
- 2 x Intel Xeon E5 V4 gen CPU (Choice of 5 options)
- 256GB, 512 GB, or 768GB DDR4 Memory
- 40GbE NIC
- 8 x 8 TB 12G SAS 7.2k RPM LFF HDD (4k)
- 1 X SAS 12G HBA
- 2 x 480GB 2.5 inch Boot SSD (Raid 1)
- TPM 2.0

Cisco Integrated System for Microsoft Azure Stack

Microsoft Scaling Limitation – Until Mid Summer 2018



Microsoft Code Limitation:

- Cannot add a node to a Scale Unit (Cluster)
- Limits all server vendors
- A future version of Azure Stack will relax this limitation (Approx. July 2018)

Use this limitation to convince customers to buy larger initial configurations NOW to ensure they have ample capacity.

Cisco Flexible Provisioning:

- Financing options to overcome a financial objection!

How To Size Azure Stack System

Based on the number of VM that the customer is forecasting to run over time.

Do:

- Educate customer on Azure VM sizings
- Discuss which workloads fit each VM size
- Factor in the growth rate and add 10%
- Be sure the customer understands current Microsoft scalability limitations
- Use the table on the following chart to evaluate config options

Do Not:

- Blindly match a competitor's configuration (Dell only sells in 4-node blocks)
- Ask what the partner is basing their sizing upon 😊
- Guess
- Assume that you can add a node to a installed cluster before July 2018
- Try to install a system in a country not already on Microsoft's approved list of counties.

[Microsoft Azure VM Sizing Detail located at:](https://docs.microsoft.com/en-us/azure/virtual-machines/windows/sizes-general)

<https://docs.microsoft.com/en-us/azure/virtual-machines/windows/sizes-general>

Sizing Assistance

You have a choice:

- 1.) Go for it, and use the chart on the next page as your guide
- 2.) Contact TSN for assistance at: tsn-request@cisco.com

Sizing Azure Stack – VM Chart

RAM Per Host	Host Count Per Scale Unit	Maximum VM Count (Standard A3)	Storage Per VM (GB)
256GB	4	27	2246
	5	39	1950
	6	52	1795
	7	64	1700
	8	76	1635
	9	89	1589
	10	101	1553
	11	113	1526
	12	126	1504
512GB	4	120	491
	5	164	456
	6	207	436
	7	251	423
	8	294	414
	9	337	407
	10	381	402
	11	424	397
	12	468	394
768GB	4	214	277
	5	288	259
	6	363	249
	7	437	243
	8	512	238
	9	586	234
	10	661	232
	11	735	229
	12	810	228

Based on system resources available to support Azure Stack workloads, assuming a A3 sized VM for all workloads, (A3 is the most popular VM size on Azure public cloud) this table provides an estimate as to the number of VMs supported.

Customer should be able to provide the number of VMs they forecast to support. You should always add 10% to the customer's VM forecast.

A3 VM = 4 vCPU cores, 7GB RAM, 256GB Temp Storage

For choice of processor, discuss with the customer the amount of oversubscription desired.

4:1 desired for highly intensive apps

7:1 desired for less intensive apps

Microsoft Azure VM Sizing Detail located at:
<https://docs.microsoft.com/en-us/azure/virtual-machines/windows/sizes-general>

Azure Stack on Cisco UCS – A Complete Solution

What are the key sales decision points for the fixed BOMs?

Cisco Support Services

On-site Installation Services

Cisco Automation Scripts

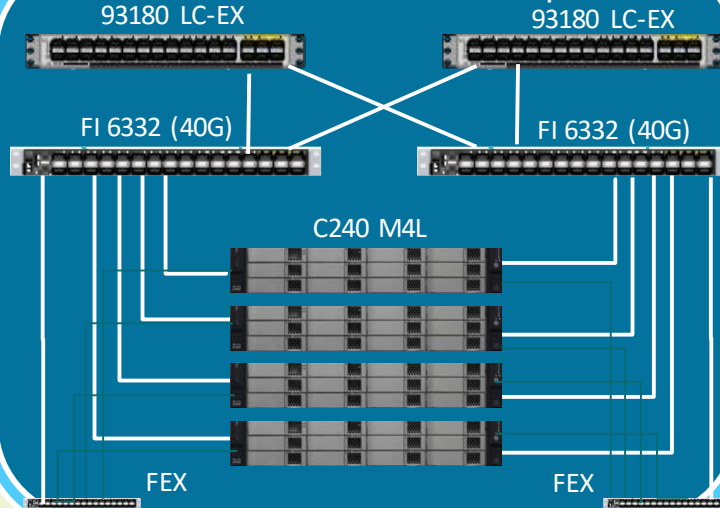

Sales Rep Order Entry Decisions:

- Select (1): Config to order (CTO), Fixed Small, Fixed Medium BOM
- Select the number of nodes, 4 min, 12 max, any # in between
- Choose processor (6 choices – CTO only)
- Choose memory amount (256, 512, 768GB – CTO only)
- System Rack is Optional

Items that sales cannot do:

- Remove or discount Cisco AS installation service
- Remove Cisco Solution Services from any component, default is 12 month term of 24 hour x 7 day x 4 hour response time
- Attempt to remove:
 - Nexus 93180 Switches
 - Nexus 2K FLX
 - Fabric Interconnects

Remember:

This solution is a fixed BOM that matches the configurations tested and certified for Azure Stack. Flexibility outside of what is allowed within the CCW rules is not allowed or supported.

↪ The BOM includes all HW and services.

Cisco Integrated System for MSFT Azure Stack

BOM Choices – Pick One

Price Discounted

UCS-MAN-S00A0T0V0

Config to Order
4-12 Nodes

UCS C240 M4L



- 2 x 3.2 TB NVMe cards
- 2 x Intel Xeon E5 V4 (Choice of 6 options)
- 256GB, 512 GB, or 768GB DDR4 Memory
- 40GbE NIC
- 8 x 8 TB 12G SAS 7.2k RPM LFF HDD (4k)
- 1 X SAS 12G HBA
- 2 x 480GB 2.5 inch Boot SSD (Raid 1)
- TPM 2.0

UCS-MAN-S00A0T1V0

Entry Config
Fixed 4 Nodes

UCS C240 M4L



- 2 x 3.2 TB NVMe cards
- 2 x Intel Xeon E52650 (12core) CPU
- 256GB DDR4 Memory
- 40GbE NIC
- 8 x 8 TB 12G SAS 7.2k RPM LFF HDD (4k)
- 1 X SAS 12G HBA
- 2 x 480GB 2.5 inch Boot SSD (Raid 1)
- TPM 2.0

UCS-MAN-S00A0T2V0

Med/Large Config
8 or 12 Nodes

UCS C240 M4L



- 2 x 3.2 TB NVMe cards
- 2 x Intel Xeon E52683 (16 core) CPU
- 512GB DDR4 Memory
- 40GbE NIC
- 8 x 8 TB 12G SAS 7.2k RPM LFF HDD (4k)
- 1 X SAS 12G HBA
- 2 x 480GB 2.5 inch Boot SSD (Raid 1)
- TPM 2.0

Choose Config-To-Order

Cisco Commerce Estimates

Rebecca Martinez

Search All...

Catalog Estimates Deals & Quotes Orders Services & Subscriptions Software

I want to ...

- View Estimate Information
- Link to Opportunity
- Set Install/Service Location
- See Recommended Global Sales Kits
- Security Subscriptions
- AS-Fixed
- Learning Credits

ESTIMATE NAME Estimate_EB75355268BW (EB75355268BW) Global Price List in US Dollars (USD)

ESTIMATE ID EB75355268BW CREATED BY Rebecca Martinez CREATED ON 20-Sep-2017

Set preferences for this estimate

UCS-MAB-B00R00 1 Add Find Products & Solutions Actions

Remove Selected Lines More

	Hardware, Software and Services	Lead Time	Unit List Price (USD)	Qty	Unit Net Price (USD)	Discount (%)	Extended Net Price (USD)
<input type="checkbox"/>	10 UCS-MAB-B00R00 more Microsoft Azure Stack Bundle 1 with configure to order node Valid as of 20-Sep-2017 04:49:47 PDT	28 days		1		0.00	

Edit Options | Select Service/Subscription | Validate | Add Note | More Actions

Estimate Total All Prices Shown in USD

Average Product Discount	0.00%	Product Total	
Average Service Discount	0.00%	Service Total	0.00
Average Subscription Discount	0.00%	Subscription Total	0.00
		Total Price	

This Price Estimate does not constitute an offer by CISCO to sell products, but is instead an invitation to issue a purchase order to CISCO until the valid date specified in this price estimate. Such a purchase order will be subject to Cisco's standard procedures, terms and conditions for the acceptance of purchase orders. This order may subject to sales tax, VAT, duty and freight charges even if not noted on this estimate.

MLB Number

Pick Nodes 4 to 12

Pick The Processor – Default is Indicated

OPTION SELECTION UCS-MAN-S00A0T0V0 part of UCS-MAB-B00R00

Global Price List in US Dollars (USD)

Configuration Summary

[View Full Summary](#)

Country Specification

Select Country (Not Required)

Category

Qty

Unit List Price (USD)

PROCESSOR

Processor Option

UCS-CPU-E52650E	2	0.00
-----------------	---	------

MEMORY

Memory Option

UCS-MR-1X322RV-A	8	0.00
------------------	---	------

Additional Memory Option

RAID CONTROLLER

RAID Controller Option

Subtotal 0.00

Estimated Lead Time 28 days

[Reset Configuration](#)

[Cancel](#)

[Done](#)

Warnings (2):

- UCS-CPU-E52650E is defaulted under Processor Option. (CE100033)
- UCS-MAN-S00A0T0V0 quantity 1 requires a minimum quantity of 2 from Power Cable Option (CE100012)

Option Search

[Multiple Options Search](#)

UCS-MAN-S00A0T0V0 > Processor Option

[Key](#)

Processor Option

SKU	Qty	Lead Time	Unit List Price (USD)
<input type="radio"/> UCS-CPU-E52683E 2.10 GHz E5-2683 v4/120W 16C/40MB Cache/DDR4 2400MHz	2	10 days	0.00
<input type="radio"/> UCS-CPU-E52660E 2.00 GHz E5-2660 v4/105W 14C/35MB Cache/DDR4 2400MHz	2	10 days	0.00
<input type="radio"/> UCS-CPU-E52698E 2.20 GHz E5-2698 v4/135W 20C/50MB Cache/DDR4 2400MHz	2	10 days	0.00
<input checked="" type="radio"/> UCS-CPU-E52650E 2.20 GHz E5-2650 v4/105W 12C/30MB Cache/DDR4 2400MHz	2	10 days	0.00
<input type="radio"/> UCS-CPU-E52699E 2.20 GHz E5-2699 v4/145W 22C/55MB Cache/DDR4 2400MHz	2	10 days	0.00
<input type="radio"/> UCS-CPU-E52695E 2.10 GHz E5-2695 v4/120W 18C/45MB Cache/DDR4 2400MHz	2	10 days	0.00

[Clear Selection](#) | [Show Incompatible SKUs](#)

Pick Memory Amount

Configuration Summary [View Full Summary](#)

Country Specification **i**
Select Country (Not Required) ▼

Category i	Qty	Unit List Price (USD)
UCS-MR-1X322RV-A IC	8	0.00
Additional Memory Option		
UCS-SP-M32-RVA	7	0.00
RAID CONTROLLER ▲		
RAID Controller Option		
UCSC-SAS12GHBA IC	1	0.00
TPM OPTIONS ▲		
TPM OPTIONS		
UCSX-TPM2-002 IC	1	0.00
Subtotal		0.00

Warnings (3):

- A selection of either 8 or 16 Additional Memory Option is allowed. Please adjust the quantity. (CE200109)
- UCS-CPU-E52650E is defaulted under Processor Option. (CE100033)
- UCS-MAN-S00A0T0V0 quantity 1 requires a minimum quantity of 2 from Power Cable Option (CE100012)

Option Search **i** Multiple Options Search

UCS-MAN-S00A0T0V0 > Additional Memory Option Key ▼

SKU	Qty	Lead Time i	Unit List Price (USD)
<input checked="" type="checkbox"/> UCS-SP-M32-RVA SVIP *** 32GB DDR4-2400-MHz RDIMM/PC4-19200/dual rank/x4/1.2v	<input type="text" value="7"/>	10 days	0.00

[Show Incompatible SKUs](#)

256GB is the default, you can adjust to 512GB or 768GB

Fixed Node BOM - # of Nodes is ONLY Choice

Cisco Commerce Configuration | John McAbel

Open a Case | Training | CCW Support Community | Cisco Feature Navigator

BUNDLE CONFIGURATION NAME UCS-MAB-B01R00 | Max. Estimated Lead Time 28 days | Global Price List in US Dollars (USD)

Set service preferences for this configuration

Warnings (3):

- Valid Configuration requires Advanced Services Pricing for installation. Please contact azurestack-as-sow@cisco.com (CE202343)
- All Azure Stack orders are under Compliance Hold checking Solution Support, AS Installation, Country support and Deal ID flagging. (CE202343)
- Solution support (24x7x4OS) must be selected for for N9K and N2K. (CE202343)

Pick Nodes
4, 8, 12

Available Components Unit List Price (USD)

SERVERS

Product	Unit List Price (USD)	Adjusted List Price (USD)	Qty	Extended List Price (USD)	Status
UCS-MAN-S00A0T1V0 Microsoft AzureStack Node-C240M4L w/E52650v 4,8x32GB,QLogic Estimated Lead Time: --	0.00	0.00	4	0.00	INVALID

Add a SERVERS from the left panel

LICENSE > 0 Selected (Min 0, Max 22)

Product	Unit List Price (USD)	Adjusted List Price (USD)	Qty	Extended List Price (USD)	Status
---------	-----------------------	---------------------------	-----	---------------------------	--------

Add a LICENSE from the left panel

FABRIC INTERCONNECT > 2 Selected (Min 2, Max 2)

Product	Unit List Price (USD)	Adjusted List Price (USD)	Qty	Extended List Price (USD)	Status
UCS-MAFI-6332 Add Custom Name Edit Options Select Services/Subscriptions Remove Line	0.00	0.00	2	0.00	INVALID

FABRIC > 4 Selected (Min 4, Max 4)

Product	Unit List Price (USD)	Adjusted List Price (USD)	Qty	Extended List Price (USD)	Status
N9K-C93180LC-EX Add Custom Name Edit Options Select Services/Subscriptions Remove Line	0.00	0.00	2	0.00	INVALID

Choose One Fixed Node Config.

Choose One Fixed Node Config.

Compliance Hold Process and Response

Compliance Hold Requirements MSFT Azure Stack (MAS)

1.) Release order to factory using this alias:
mas_comphold_release@cisco.com
2.) If order placed via partner, e-mail customer name and partner to azurestack-presales@cisco.com

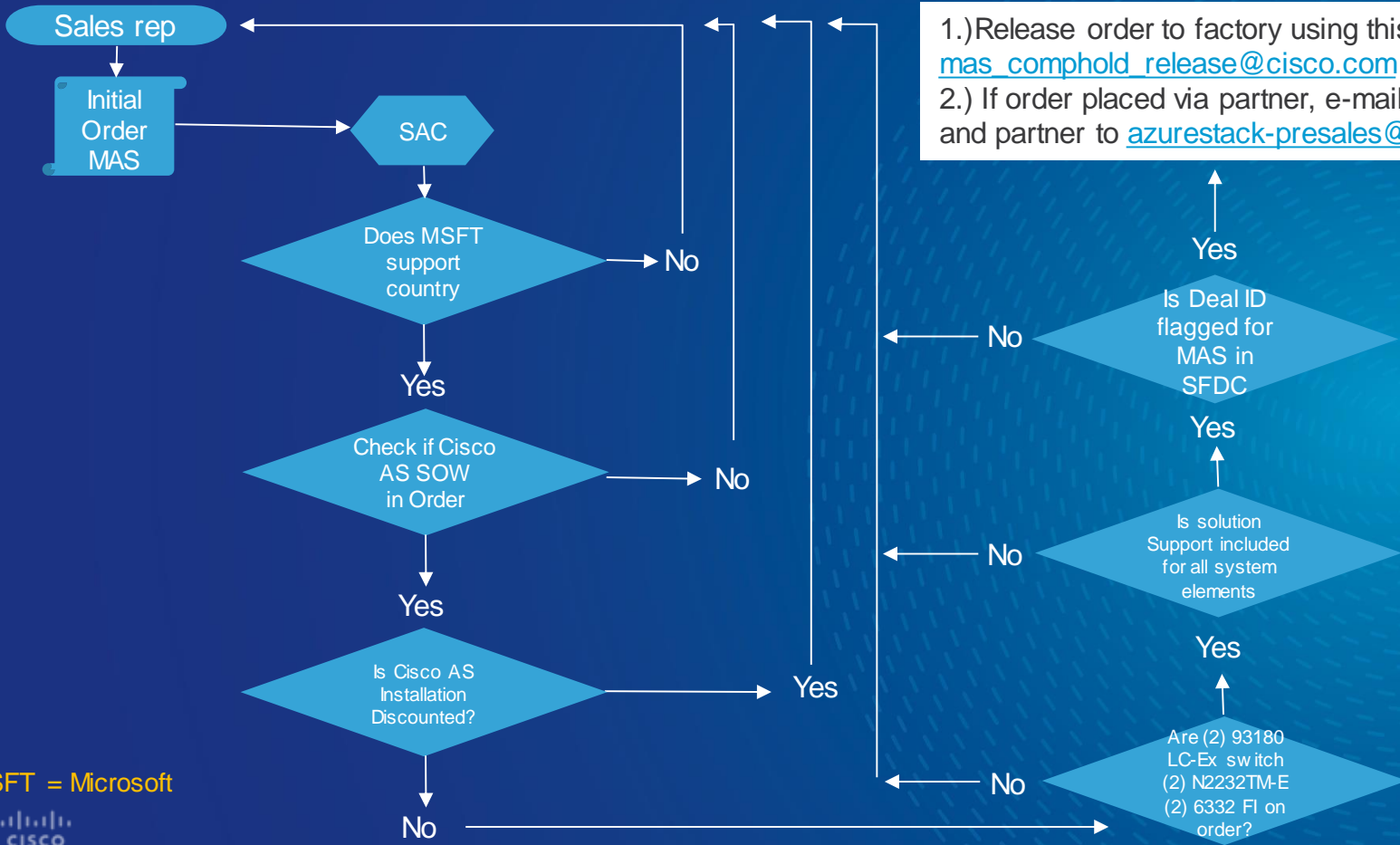

MSFT = Microsoft



Current List of Microsoft Supported Countries

As of Oct 3, 2017

<u>Geo</u>	<u>Countries</u>
AMER	Argentina
AMER	Brazil
AMER	Canada
AMER	Chile
AMER	Colombia
AMER	Mexico
AMER	Peru
AMER	Puerto Rico
AMER	United States
AMER	US Virgin Islands
AMER	Uruguay

<u>Geo</u>	<u>Countries</u>
APJC	Australia
APJC	Hong Kong
APJC	India
APJC	Indonesia
APJC	Japan
APJC	Korea
APJC	Malaysia
APJC	New Zealand
APJC	Philippines
APJC	Singapore
APJC	Taiwan
APJC	Thailand
APJC	Vietnam

<u>Geo</u>	<u>Countries</u>
EMEA	Austria
EMEA	Belgium
EMEA	Denmark
EMEA	Finland
EMEA	France
EMEA	Germany
EMEA	Ireland
EMEA	Israel
EMEA	Italy
EMEA	Luxembourg
EMEA	Monaco
EMEA	Morocco
EMEA	Netherlands
EMEA	Norway
EMEA	Portugal
EMEA	Russia
EMEA	Saudi Arabia
EMEA	SouthAfrica
EMEA	Spain
EMEA	Sweden
EMEA	Switzerland
EMEA	Turkey
EMEA	United Arab Emirates
EMEA	United Kingdom

Note:

If the planned installation location is in a country not on this list, then the order must be rejected and sent back to the sales team.

More countries will be added to this list over time but Microsoft has not provided a schedule as to when that will occur.

How to Contact SAC?

- **Email:** sac-support@cisco.com
- **Phone:** +1-(919)-858-6385
- **Live Chat:**
<https://ciscosales.webex.com/ciscosales/supportcenter/webacd.wbx?WQID=8b72d294f70a04e6e0ba11729923363c&refURL=>
- **SAC is open 24 x 5, all countries, all time zones**
- **English language support**



SFDC Solution Tagging – Azure Stack

Tagging Azure Stack Opportunities in SFDC

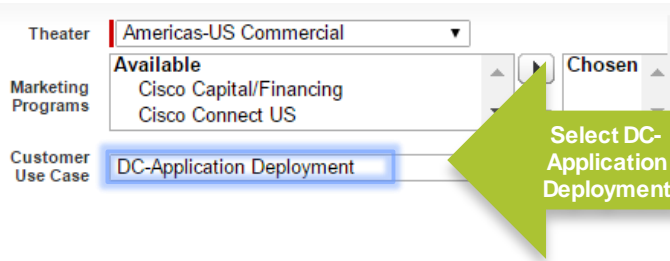
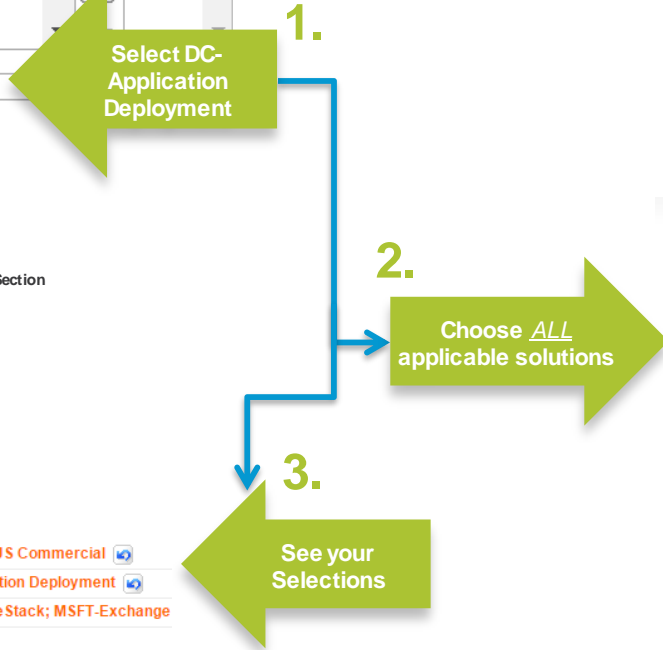
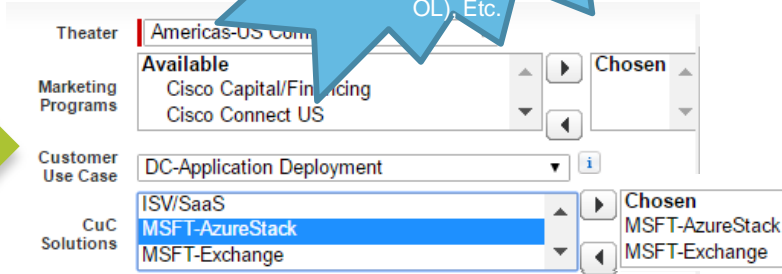

Figure 1 – SFDC Opportunity page, Additional Information Section



You can choose multiple solutions that apply to your deal...

Ex. MSFT Azure Stack, MSFT- Exchange, AND Oracle-Platform (DB,RAC,OVM, OL), Etc.



Remember: Please keep the 'expected book date' current!

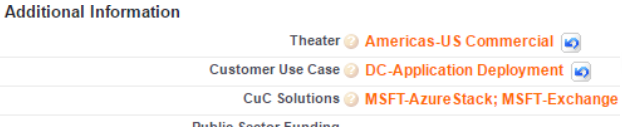

Thank you for your support in our effort to increase visibility of Cisco's Key Solutions!

Tagging Azure Stack PSS Workspaces in SFDC

Workspace Details

Workspace Team: -None-

Workspace Technology: **COMPUTING SYSTEMS**

Workspace Sub Technology: -None-

Workspace Product: **Not Applicable**

Figure 1 – SFDC Opportunity Workspace page, Workspace Details Section

Use Case Information

Business Driver: --None--

Solution Offer: --None--

Application: **MSFT-AzureStack**

- None--
- MSFT-AzureStack
- MSFT Exchange
- MSFT Hyper-V
- MSFT Office
- MSFT Sharepoint
- MSFT SQL
- MSFT System Center
- MSFT Win 2003 Migration
- MSFT Windows Platform

Figure 2 – SFDC Opportunity Workspace page, Use Case Information Section

Remember:

Please keep the **'expected book date'** current!

Thank you for your support in our effort to increase visibility of Cisco's Key Solutions!

Why should you tag your opportunities?

- Sales reporting is a contractual requirement with Microsoft
- Dictates resource allocation i.e. more FREE Firefly training in your area
- Increase internal visibility on solutions which helps Cisco take advantage of market opportunities
- Tagging helps to prioritize support (features, TAC, monitoring)
- Investment- which solutions do we continue to fund or cut back, where do we invest & allocate more dollars
- Solution forecasting – ensure forecast accuracy, helps determine where to allocate quarterly resources (sales, TAC, etc)
- Helps Cisco prioritize and focus efforts in the right areas – product features, road maps, right products at the right price
- 3rd party reference support (IDC, Gartner, MSFT)

SFDC TAGGING = Better, more effective business decisions which leads to Higher Revenue, Lower cost

Sales Materials Available With Announcement

Review sales materials - <https://salesconnect.cisco.com/#/briefcase-details/P01180590>

- Press Release
- FAQ
- High level solution massaging Deck
- BDM Deck
- BLOGS
- Whitepaper - **Microsoft Azure Stack Technical Preview on Cisco UCS C-Series Rack Servers**
- At A Glance
- Sales Connect Web Page Azure Stack Briefcase - <https://salesconnect.cisco.com/#/briefcase-details/P01180590>
- External Customer Web Page - <http://www.cisco.com/c/en/us/solutions/data-center/integrated-system-microsoft-azure-stack/index.html>

Questions: azurestack-presales@cisco.com

Questions – Need Assistance?

Cisco Azure Stack Sales
Connect Site:

[https://salesconnect.cisco.com/
open.html?b=P01180590](https://salesconnect.cisco.com/open.html?b=P01180590)

If you have questions
please send a mail to:

[Azurestack-
presales@cisco.com](mailto:Azurestack-presales@cisco.com)

For configuration assistance
contact TSN at:

tsn-request@cisco.com



For more information and the latest news:

[www.cisco.com/content/en/us/solutions/data-
center/integrated-system-microsoft-azure-stack](http://www.cisco.com/content/en/us/solutions/data-center/integrated-system-microsoft-azure-stack)



Back Up Charts